

CE

90 Litre Pneumatic Oil Drainer

IMPORTANT! PLEASE READ THESE INSTRUCTIONS CAREFULLY. NOTE ALL SAFETY INSTRUCTIONS AND WARNINGS. USE THE PRODUCT CORRECTLY AND WITH CARE FOR THE PURPOSE FOR WHICH IT IS INTENDED. FAILURE TO FOLLOW THESE INSTRUCTIONS MAY CAUSE DAMAGE TO PROPERTY AND/OR PERSONAL INJURY.

PLEASE KEEP THESE INSTRUCTIONS SAFE AND AVAILABLE FOR FUTURE REFERENCE.

CERTIFICATE OF GUARANTEE

This product is guaranteed for a period of 2 Years, with effect from the date of purchase and applies only to the original purchaser. This guarantee only applies to defects arising from, defective materials and or faulty workmanship that become evident during the guarantee period only and does not include consumable items. The manufacturer will repair or replace the product at their discretion subject to the following. That the product has been used in accordance with the guidelines as detailed in the product manual and that it has not been subjected to misuse, abuse or used for a purpose for which it was not intended. That it has not been taken apart or tampered with in any way whatsoever or has been serviced by unauthorised persons or has been used for hire purposes. Transit damage is excluded from this guarantee, for such damage the transport company is responsible. Claims made under this guarantee must be made in the first instance, directly to the retailer within the guarantee period. Only under exceptional circumstances should the product be returned to the manufacturer. In this case it shall be the consumer's responsibility to return the product at their cost ensuring that the product is adequately packed to prevent transit damage and must be accompanied with a brief description of the fault and a copy of the receipt or other proof of purchase. The manufacturer shall not be liable for any special, exemplary, direct, indirect, incidental, or consequential loss or damage under this guarantee. This guarantee is in addition to and does not affect any rights, which the consumer may have by virtue of the Sale of Goods Act 1973 as amended 1975 and 1999.

INTRODUCTION

Thank you for purchasing this product which has passed through our extensive quality assurance process. Every care has been taken to ensure that it reaches you in perfect condition. However, in the unlikely event that you should experience a problem, or if we can offer any assistance or advice please do not hesitate to contact our customer care department. For details of your nearest customer care department please refer to the telephone numbers at the back of this manual.

Safety First

Before attempting to operate this product the following basic safety precautions should always be taken to reduce the risk of fire, electric shock and personal injury. It is important to read the instruction manual to understand the application, limitations and potential hazards associated with this product.

HELPLINE & SPARE PARTS

In the unlikely event of a defect occurring please contact our Helpline.
Office hours: Monday - Friday 9:00am - 5:00pm. Telephone Number 01332 576 850

INTENDED USE

The 90 Litre Pneumatic Oil Drainer will provide years of reliable operation. It is designed to collect used oil, transmission fluid and anti-freeze in its large 23 gallon reservoir and allow easy transfer of these fluids by pressurizing the tank with approximately 8PSI of shop air.

TECHNICAL SPECIFICATIONS

Description: 90 Litre Pneumatic Oil Drainer
Model: SPOD90
Volume of Oil Tube: 90L
Oil Capacity: <70L
Air pressure when pumping oil: 1-2Bar
Air pressure when expelling oil: $\leq 0.5\text{Bar}$

Vacuum range: 0.1-0.2atm
The maximum temperature: 70°C
Metal Suction Pipe Size: Nylon 8x950 Length
Products Size: 500x500x1600 mm
Own weight: ca. 26 kg

SAFETY INSTRUCTIONS

Do not extract caustic or flammable products. Do not expose the reservoir to any source of heat. Do not do any welding on the reservoir.

While extracting high temperature oils, keep hands and face protected. Only use the device for the purpose of which it has been designed. Do not modify any component of the equipment. Only use original spare parts.

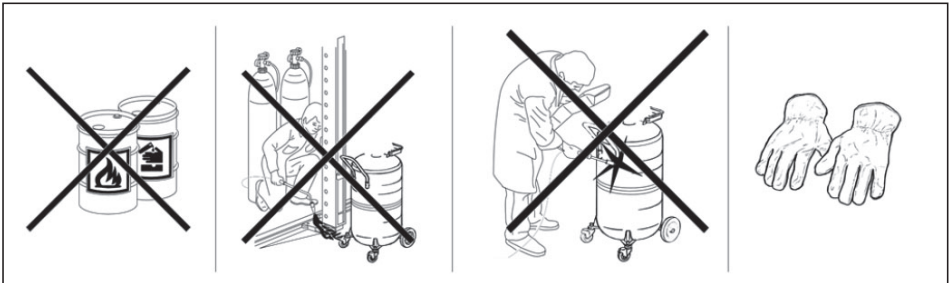

Do not drain caustic or flammable products

Do not expose the tank to any source of heat

Do not do any welding on the tank

While draining high temperature oils, keep hands and face protected

ASSEMBLY

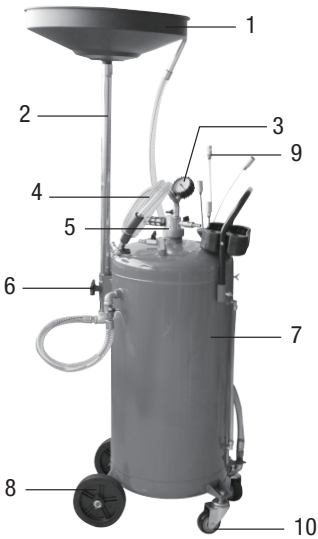

1. Collection bowl
2. Stand bar
3. Vacuum gauge
4. Oil hose
5. Vacuum generator
6. Lock screw
7. Oil tank
8. Wheel
9. Suck pipe
10. Swivel Casters

Raising and lowering the Collection bowl

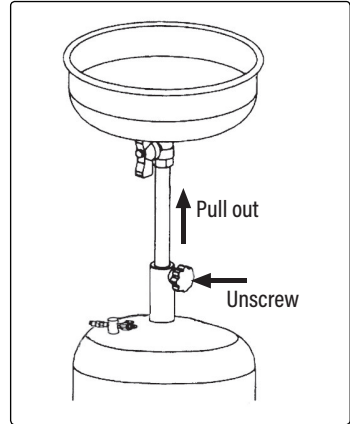

Step 1: Loosen the Lock Screw (6)

Step 2: Raise or lower the Collection Bowl (1) to the required height

Step 3: Tighten Lock Screw (6)

1. Insert the handle into its seat and secure with the screws provided. Attach the hose clamp retainer E. Position the tool tray D. (Pic. 1)
2. Check to see if the male adapter A supplied with the unit, is compatible with your shop air system's quick coupler. If it is not, replace it with a suitable 1/4" male adapter. (Pic. 2)
3. Connect the drain hose to the ball valve on the base of the units tank and tighten with the hose clamp C provided. (Pic. 3)

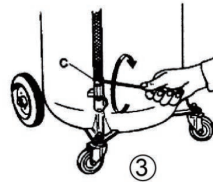
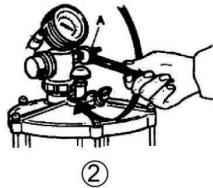
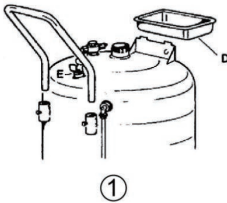

CHARGING THE SYSTEM

4. Completely open valve B by turning it counter clockwise. (Pic. 4)
5. Close the suction ball valve C. (Pic. 5)
6. Hand tighten (close) the air valve D by turning it clockwise. (Pic. 6)
7. Close the valve E by turning it 90 degrees. (Pic. 7)
8. Connect shop air (1-2Bar) to male adaptor A. Air will flow through the muffler until the gauge approaches the red field (after about 2.5-3min). Disconnect the shop pair. (Pic. 8)

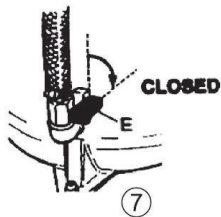
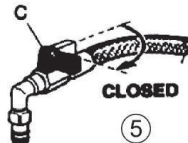
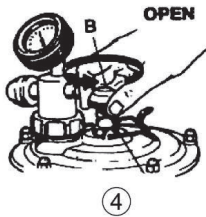

9. The unit is now depressurized and ready for use.

OPERATION

Oil should always be removed when hot (70-80°C). The suction capacity of the unit is equal to 2/3 of its reservoir capacity.

1. With the engine still warm, remove the dipstick and insert the largest possible probe as far down as it will go. (Pic. 9)
2. Connect the suction hose to the probe. (Pic. 10)
3. Open ball valve C, keeping the probe dipped in the oil. The oil is sucked from the sump into the graduated transparent chamber where it can be inspected. (Pic. 11)

To transfer fluids from the transparent chamber to the reservoir tank press down on valve B and secure it with the metal lock provided. Always do this operation when the oil is hot. It is also possible to suck hot oil keeping the air hooked up to the device.

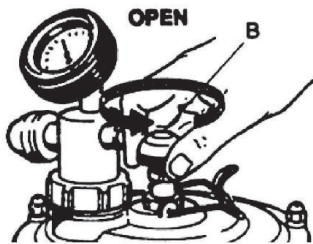
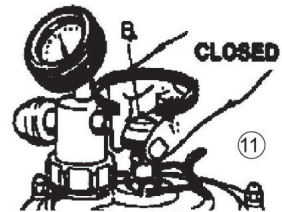
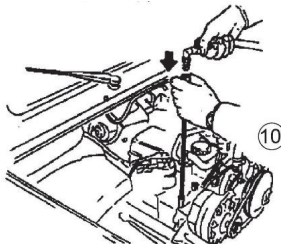
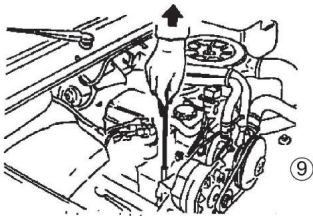

WARNING! Before draining the oil from the transparent chamber into the main reservoir, valve B must be open.



WARNING! Never fill the transparent chamber over the stop mark.

WARNING! Never fill the reservoir over the limit indicated by the side gauge.

OPERATION

SOMETIMES OIL LEAKS OUT OF THE MUFFLER. THIS CAN WHEN:

1. Oil is sucked, keeping air continuously connected to the equipment and the transparent chamber is filled over the STOP mark on the bowl.
2. Oil is discharged from the transparent bowl into the lower reservoir without opening valve B (turning it counter clockwise). It is not necessary to open the valve B only when the lower reservoir is depressurized (When there is a vacuum).

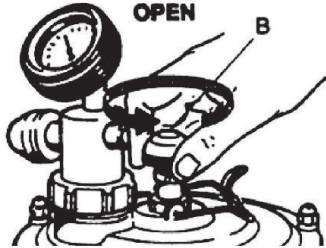

3. When the equipment is moved and the transparent chamber is full of oil.

In this case proceed as follows: remove the muffler, dismantle it and clean all the components.

Hold a rag as indicated, connect the compressed air to the device until all the oil comes out of the Venturi group. Reassemble and mount the muffler again. **EMPTYING THE RESERVOIR**

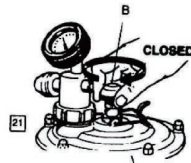

IMPORTANT!

Make sure that valve B is in its upper position and closed (tuned clockwise).

Open the ball valve C. Connect shop air (1-2Bar) to valve E until all fluids have been transferred from the unit's storage tank. The unit storage tank has been equipped with a pneumatic safety valve calibrated at 14 PSI-1BAR.



PARTS LIST

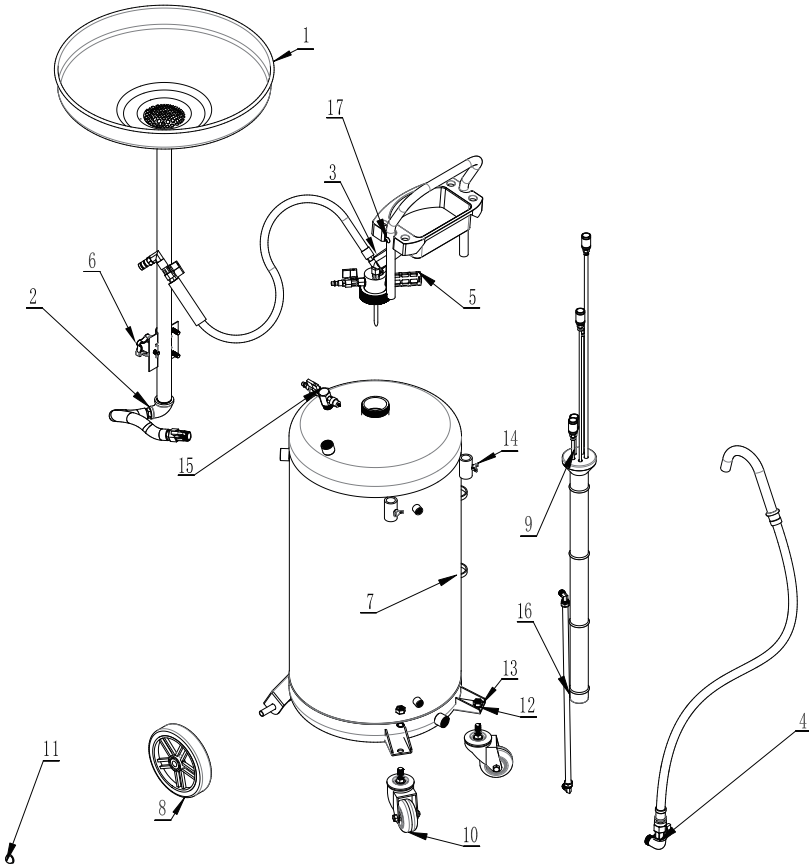

No.	Part No.	Qty
1	Collection Bowl	1
2	Support Rod 19 Steel Wire Tube Assembly	1
3	Vacuum Gauge	1
4	Discharge Oil Hose	1
5	Air Filter	1
6	Lock Screw	1
7	Oil Tank	1
8	7 Inch Caster	2
9	Hexagonal Tee Assembly	1

No.	Part No.	Qty
10	3 Inch Swivel Casters	2
11	Buckle	2
12	M10 Spring Washer	2
13	M12 Nut	2
14	8x10 Wing Screw	2
15	Hexagonal Tee Assembly	1
16	Adjusting Steel Tube	1
17	Parts Tray	1

TROUBLESHOOTING

Problem	Possible Cause	Remedy
Pressure not dropping on air pressure gauge	Valve left open.	Close valve correctly.
	Incorrect air pressure value.	Check the correct pressure required. Please refer to technical specifications.
Oil not pumping even with correct pressure	Poor seal between air supply and suction hose.	Check engine is still warm.
	Suction hose valve closed.	Open the valve.
	Suction hose blocked or touching bottom of the tank.	Clean hose or reposition in tank.

EC DECLARATION OF CONFORMITY

1. Product models: SOD90

2. Name and address of the manufacturer or his authorised representative:



SGS Engineering (UK) Ltd
Unit 1 West Side Park, Raynesway, Derby, DE21 7AZ
Telephone: +44 (0)1332 576 850

3. This declaration of conformity is issued under the sole responsibility of the manufacturer.

4. Object of the declaration:

Equipment: 90 LITRE PNEUMATIC OIL DRAINER

Brand name: SGS

5. The object of the declaration described above is in conformity with the relevant statutory requirements:

2014/68/EU (Pressure Equipment)

6. References to the relevant designated standards used or references to the other technical specifications in relation to which conformity is declared:

EN 13445-1:2021, EN 13445-2:2021, EN 13445-3:2021,
EN 13445-4:2021

7. The person authorized to compile the technical file:

Name: Neil Sansom

Address: SGS Engineering (UK) Ltd, Unit 1 West Side Park, Raynesway, Derby, DE21 7AZ

Signed for and on behalf of:

Authorised Representative

A handwritten signature in black ink, appearing to read 'Neil Sansom', written over a horizontal line.

Neil Sansom, CEO
Date: 17/11/2025

